

# **TRAC REGULATOR CO., INC.**

## **STYLE 'B'**

### **THERMOSTATIC TEMPERATURE REGULATOR**

MIL-V-19772A and MIL-DTL-19772B

TYPE I (3-WAY) / TYPE II CLASS 1 / TYPE II CLASS 2  
WITH MANUAL OVERRIDE and OVERHEAT  
PROTECTION

SUITABLE FOR SHIPBOARD SERVICE



**TRAC Regulator Company Inc.**  
160 South Terrace Avenue  
Mount Vernon, New York USA 10550-2408

Phone: (914) 699-9352  
Fax: (914) 699-9367



## **GENERAL INFORMATION**

### **INTRODUCTION**

The Trac Style 'B' Temperature Regulator is a self sensing and self actuated temperature regulating valve which will automatically control liquid or steam flow through the valve in response to changes in the temperature of the controlling medium. The regulating valve requires no external source of power to operate the valve or to detect changes in the temperature of the controlling medium. The valve can be set to control at any temperature within the limits of the temperature range stamped on the nameplate.

### **PRINCIPLES OF OPERATION**

The actuator of the Trac Style 'B' Temperature Regulator is a hermetically sealed system consisting of a thermostatic sensing bulb which is connected to a bellows assembly by armored capillary tubing. Upon an increase in temperature at the sensing bulb the liquid within the bulb expands and begins to generate vapor pressure. The vapor pressure generated within the bulb is transmitted through the capillary tubing to the bellows, causing it to expand. The bellows amplifies the vapor pressure, generating the necessary thrust to operate the valve. An increase in temperature at the bulb tends to push the stem downward.

The bracket assembly consists of the bracket (yoke), adjusting screw, adjusting spring, upper pushrod, and adjusting wheel. As described above, bellows expansion in the actuator applies a downward force on the upper pushrod. The adjusting spring applies an upward force on the stem opposing the thrust of the bellows. The more spring compression applied to the adjusting spring by the adjusting wheel, the higher the controlling (set) temperature.

### **VALVE ACTION**

The Trac Style 'B' Temperature Regulator is available in three basic types of valve action:

Note: The military specification type and class generally associated with each type of valve action is included below. Departures from the military specification valve are available- these modifications include but are not limited to changes in body material, trim material, end connections, and rated pressure.

**DIRECT ACTING:** Direct acting valves are used for heating services where a rise in temperature tends to close the valve. A direct acting valve is generally used for controlling the temperature of any steam heated systems such as hot water tanks, steam tables, sterilizing equipment, etc...

MIL-V-19772A / MIL-DTL-19772B TYPE II CLASS 1 (Non-Failsafe)

**REVERSE ACTING:** Reverse acting valves are used for cooling services where a rise in temperature tends to open the valve. A reverse acting valve is generally used for controlling the temperature of cooling system recirculating lines, heat exchangers, environmental air cooling, etc...

MIL-V-19772A / MIL-DTL-19772B TYPE II CLASS 2 (Non-Failsafe)

**THREE WAY:** 3-Way valves are used for mixing hot and cold liquids to deliver liquid to the outlet at a predetermined temperature, or to divert the inlet flow of liquid to a heat exchanger or bypass based on the controlling condition.

MIL-V-19772A / MIL-DTL-19772B TYPE I (Non-Failsafe)

## BODY AND TRIM CATEGORIES

### DIRECT ACTING (A RISE IN TEMPERATURE CLOSES THE VALVE)

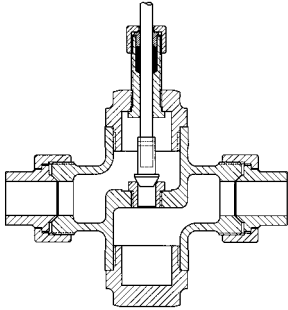

#### SINGLE SEAT (CONE DISC)

AVAILABLE SIZES: 1/4" THRU 1/2"

BODY: BRONZE  
TRIM: STAINLESS STEEL  
SILBRAZ UNION END PER MIL-F-1183  
(For availability of flanged end or NTP tailpiece  
consult factory)  
VALVE SPECIFICATION: COMMERCIAL  
PRESSURE RATING (PSIG): 100, 150, 250

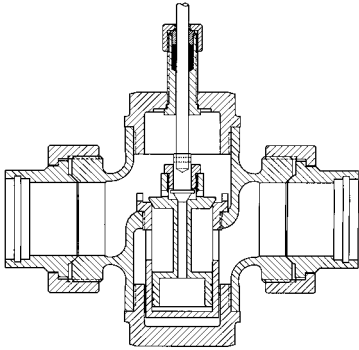

#### BALANCED SINGLE SEAT

AVAILABLE SIZES: 1/2" THRU 2"

BODY: BRONZE  
TRIM: STAINLESS STEEL  
SILBRAZ UNION END PER MIL-F-1183  
(For availability of flanged end or NTP tailpiece  
consult factory)  
VALVE SPECIFICATION: TYPE II CLASS 1  
PRESSURE RATING (PSIG): 100, 150, 250

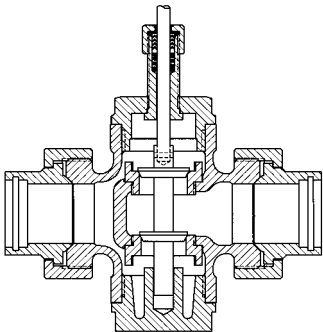

#### DOUBLE SEAT DIRECT ACTING (UNION)

AVAILABLE SIZES: 1/4" THRU 2"

BODY: BRONZE  
TRIM: BRONZE, STAINLESS STEEL, or MONEL  
SILBRAZ UNION END PER MIL-F-1183  
(For availability of NTP tailpiece consult factory)  
VALVE SPECIFICATION: TYPE II CLASS 1  
PRESSURE RATING (PSIG): 100, 150, 250

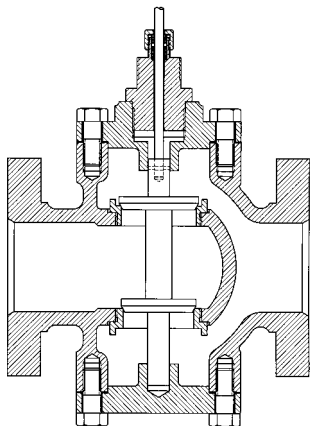

#### DOUBLE SEAT DIRECT ACTING (FLANGED)

STANDARD SIZES: 2-1/2" THRU 5"

AVAILABLE SIZES: 1/2" THRU 5"

BODY: BRONZE  
TRIM: BRONZE, STAINLESS STEEL, or MONEL  
FLANGED END PER MIL-F-20042  
(For availability of flanged end per ANSI-B16.24 or  
ANSI-B16.5 consult factory)  
VALVE SPECIFICATION: TYPE II CLASS 1  
PRESSURE RATING (PSIG): 100, 150, 250

## BODY AND TRIM CATEGORIES

### REVERSE ACTING (A RISE IN TEMPERATURE OPENS THE VALVE)

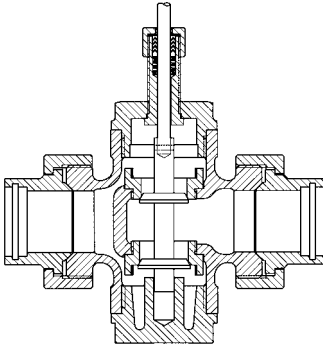

#### DOUBLE SEAT REVERSE ACTING (UNION)

AVAILABLE SIZES: 1/4" THRU 2"

BODY: BRONZE

TRIM: BRONZE, STAINLESS STEEL, or MONEL  
SILBRAZ UNION END PER MIL-F-1183

(For availability of NTP tailpiece consult factory)

VALVE SPECIFICATION: TYPE II CLASS 2

PRESSURE RATING (PSIG): 100, 150, 250

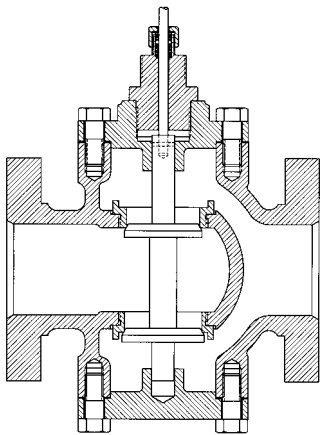

#### DOUBLE SEAT REVERSE ACTING (FLANGED)

STANDARD SIZES: 2-1/2" THRU 5"

AVAILABLE SIZES: 1/2" THRU 5"

BODY: BRONZE

TRIM: BRONZE, STAINLESS STEEL, or MONEL  
FLANGED END PER MIL-F-20042

(For availability of flanged end per ANSI-B16.24 or  
ANSI-B16.5 consult factory)

VALVE SPECIFICATION: TYPE II CLASS 2

PRESSURE RATING (PSIG): 100, 150, 250

**BODY AND TRIM CATEGORIES**

**3-WAY**

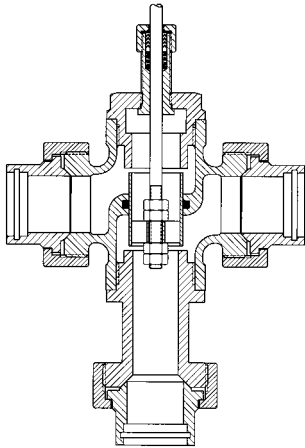

**3-WAY (UNION)**

AVAILABLE SIZES: 1/4" THRU 2"  
 BODY: BRONZE  
 TRIM: BRONZE, STAINLESS STEEL, or  
 MONEL  
 SILBRAZ UNION END PER MIL-F-1183  
 VALVE SPECIFICATION: TYPE I  
 PRESSURE RATING (PSIG): 100, 150

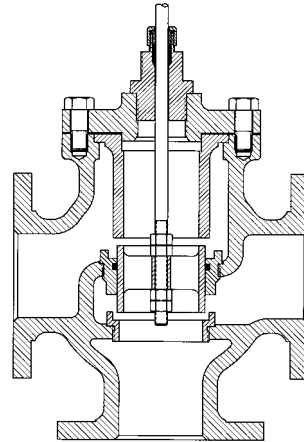

**3-WAY (FLANGED)**

STANDARD SIZES: 2-1/2" THRU 6"  
 AVAILABLE SIZES: 1/2" THRU 6"  
 BODY: BRONZE  
 TRIM: BRONZE, STAINLESS STEEL, or  
 MONEL  
 FLANGED END PER MIL-F-20042  
 (For availability of flanged end per ANSI-  
 B16.24 or ANSI-B16.5 consult factory)  
 VALVE SPECIFICATION: TYPE I  
 PRESSURE RATING (PSIG): 100, 150

**3-WAY MIXING AND DIVERTING SERVICE**  
 (A RISE IN TEMPERATURE CLOSES PORT B AND OPENS PORT C)

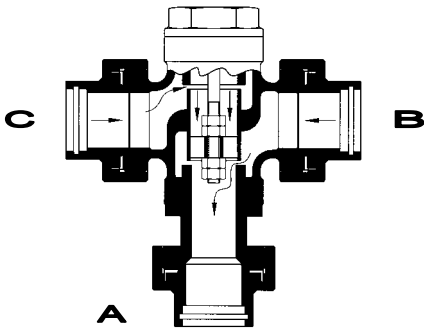

**3-WAY (MIXING SERVICE)**

BODY TAGS

PORT A: OUTLET  
 PORT B: HOT INLET  
 PORT C: COLD INLET

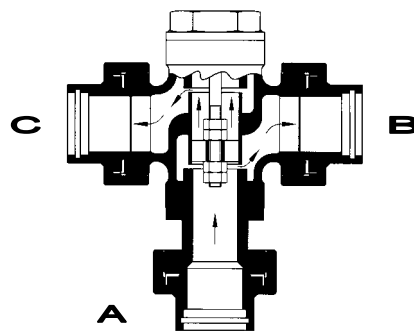

**3-WAY (DIVERTING SERVICE)**

BODY TAGS

PORT A: INLET  
 PORT B: BYPASS  
 PORT C: COOLER

## DETAILED DESCRIPTION

### FAIL POSITION

Should the thermostatic element fail in operation, the bellows will not apply any downward thrust on the valve stem and the adjusting spring will push the stem upward. The failure mode will depend on the type valve action of the installed regulator. Fail position for the three basic types of valve action are as follows:

DIRECT ACTING: Fails Open (In a heating system service the valve fails hot)

REVERSE ACTING: Fails Closed (In a cooling system service the valve fails hot)

THREE WAY (Mixing Service): Fails Hot (Cold seat shut)

THREE WAY (Diverting Service): Fails To Bypass (Cooler seat shut)

### MANUAL OVERRIDE

The manual override feature is furnished on all Trac Style 'B' production valves. It provides for uninterrupted service in the event that the thermostatic element fails in operation. By adjusting the manual override wheel, the operator can modulate the valve to any position between full open and full closed. See figure 1 for details.

To manually control the regulator, remove all spring tension from the adjusting spring by turning the adjusting wheel clockwise (looking from the top of the regulator). Turn the manual override wheel clockwise (looking from the top of the regulator) until it touches the cross pin in the valve stem. Further adjustment beyond this point will force the valve plunger or piston downward. By monitoring system thermometers, the operator can set the valve to any position which satisfies system requirements.

Note: The manual override feature should only be engaged if the thermostatic element has failed. It is not recommended to use this feature for test purposes with an operable thermostatic element- doing so may damage the actuator or bend the cross pin.

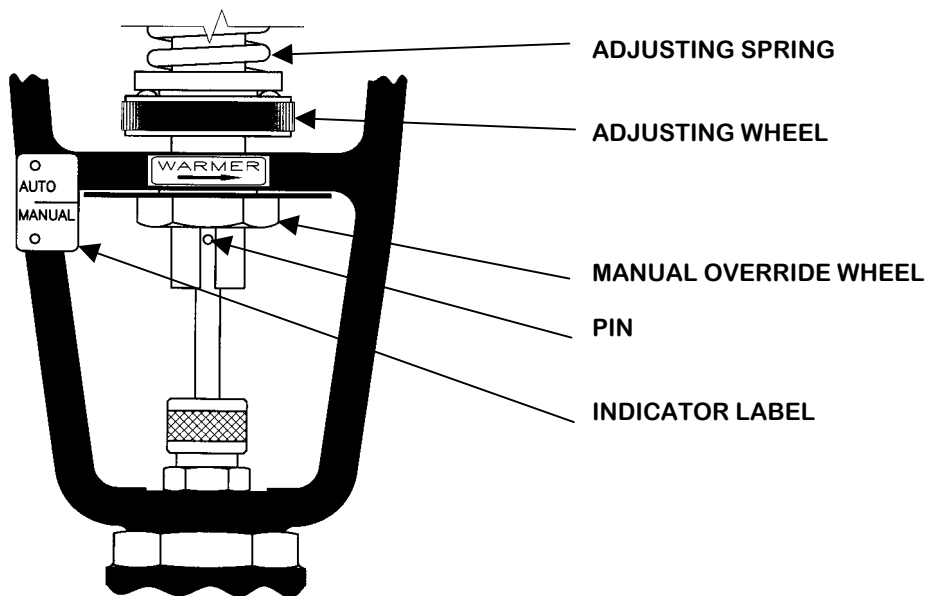

Figure 1- BRACKET ASSEMBLY

## THERMOSTATIC ELEMENT SELECTION

### STANDARD BULB (SILBRAZ/ SOCKET WELD)

The Standard bulb is provided with an 1-1/2" Brass Silbraz bulb bushing (socket weld is available). The copper capillary is armored along its entire length and is reinforced at both ends (Stainless steel capillary and armor are available upon request).

**BULB MATERIALS:** COPPER, STEEL, STAINLESS STEEL, COPPER/NICKEL, MONEL

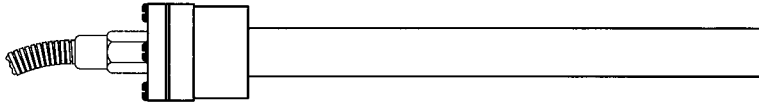

### STANDARD BULB (FLANGED)

The flanged bulb is available in accordance with the following flange specifications.

**FLANGE SPECIFICATIONS:** MIL-F-20042, ANSI-B16.24, ANSI-B16.5

(Stainless steel capillary and armor are available upon request).

**BULB/FLANGE MATERIALS:** COPPER/BRONZE, STEEL, STAINLESS STEEL, MONEL

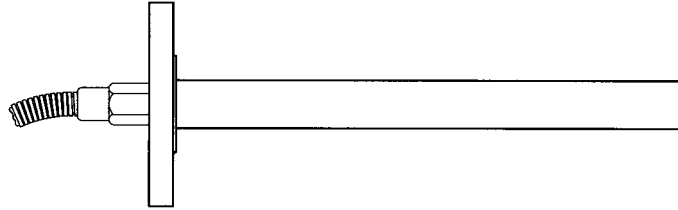

<b>STANDARD BULB DIMENSIONS (SILBRAZ/ SOCKET WELD &amp; FLANGED)</b>			
BODY STYLE	VALVE SIZE	Ranges Starting Over 120 Deg.F	Ranges Starting Under 120 Deg.F
TWO WAY	1/4" to 2"	5/8" x 11"	1" x 12"
	2-1/2" to 5"	1" x 12"	1-1/8" x 30"
THREE WAY	1/2" to 2"	5/8" x 11"	1" x 12"
	2-1/2"	1" x 15"	1-1/8" x 36"
	3" to 6"	1" x 19"	1-1/8" x 36"

### FINNED BULB

The finned bulb is designed for air duct mounting and is provided with a duct mounting flange kit. The copper capillary is armored along its entire length and is reinforced at both ends.

**BULB MATERIAL:** COPPER

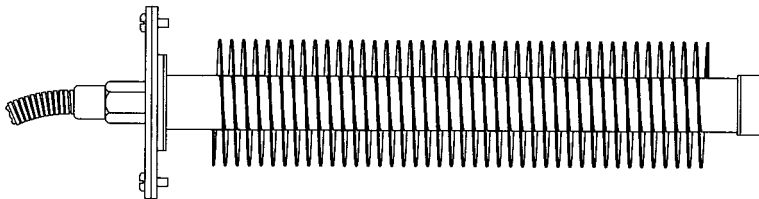

<b>FINNED BULB DIMENSIONS</b>		
VALVE SIZE	Ranges Starting Over 120 Deg.F	Ranges Starting Under 120 Deg.F
1/4" to 2"	1-1/8" OD fins x 12"	1-3/4" OD fins x 12"
2-1/2" to 5"	1-3/4" OD fins x 12"	1-7/8" OD fins x 30"



## INSTALLATION

The temperature regulating valve must be clean and free from packing material and other foreign matter before installing into a clean pipeline. Connect the valve into the pipe line so that the flow is in the direction indicated by the arrow cast on the body. The valve will work equally well in any position, but it is preferable to install the valve with the adjusting spring vertically upward. This will minimize wear on all moving parts.

### LOCATION AND INSTALLATION OF THERMAL BULB

Correct bulb position and bulb location are vitally important factors in obtaining accurate temperature control.

BULB POSITION (See figure 2 for details)

The standard thermostatic element can be installed horizontally, vertically, or at any other angle as long as the bulb mounting flange is uppermost.

When mounting the bulb horizontally, be sure that the word "TOP" stamped on the bulb mounting flange is on top. The bolt pattern for the four (4) stainless steel screws in the figure below is shown rotated by 45 degrees. When brazing or welding the bulb bushing into the piping system, be sure that the bolt pattern straddles the horizontal and vertical center lines.

The standard thermostatic element cannot be installed vertically with the bulb mounting flange lowermost. For this type of installation a Vertical Bottom Mount (VBM) thermostatic element must be specified.

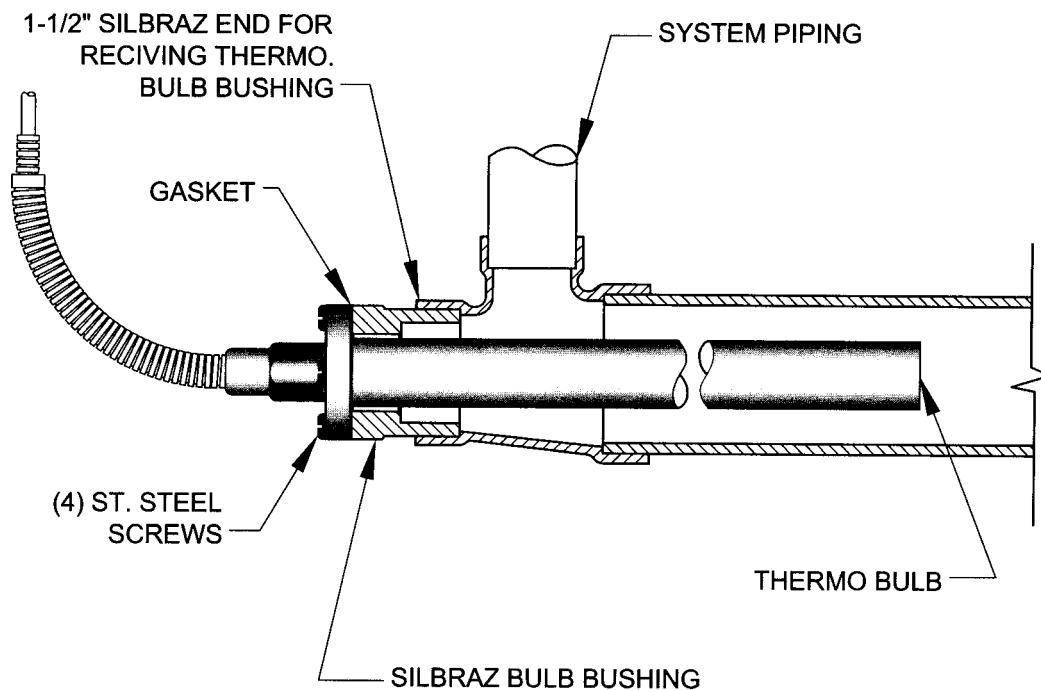

Figure 2- HORIZONTAL TEE INSTALLATION

## **INSTALLATION**

### **LOCATION AND INSTALLATION OF THERMAL BULB**

BULB LOCATION (See Typical Installations for details)

**INSTANTANEOUS HEATERS:** The bulb should be installed in the heater outlet line and as close as possible to the point where this line comes out of the heater.

**STORAGE HEATERS:** The bulb should be installed in the storage heater tank higher than the heating surface or coil, but not directly over it. The bulb should be no closer than 4 inches to the heating surface.

**3-WAY REGULATOR:** The bulb should be installed as close as possible to the regulator. For mixing service the bulb should be installed in the common outlet line. For diverting service the bulb should be installed in the common inlet line.

**ADDITIONAL COMMENTS:**

When the bulb is installed in a Tee fitting, ensure that the maximum possible surface of the bulb is in contact with the flow of the controlling medium. Installation of the bulb in dead areas of piping is to be avoided.

It is recommended that the length of pipe containing the bulb be enlarged to ensure unrestricted flow around the bulb.

For optimal regulation accuracy, the capillary length should be kept to a minimum.

Separable socket wells are available in order to remove the thermo element without draining the system. Using a separable socket well generally will slow the response time of the regulator.

### **SEPARABLE SOCKET WELL**

Separable socket wells are available with silbraz, socket weld, NPT, or flanged connections in accordance with the following specifications.

**BUSHING TYPE:** 1-1/2" SILBRAZ/SOCKET WELD (MIL-F-1183/NAVSEA 803 6397430)  
(NPT per ANSI/ASME B1.20.1 available upon request)

**BULB/BUSHING MATERIALS:** COPPER/BRASS, STEEL, STAINLESS STEEL, MONEL,  
COPPER NICKEL

**FLANGE SPECIFICATIONS:** MIL-F-20042, ANSI-B16.24, ANSI-B16.5

**BULB/FLANGE MATERIALS:** COPPER/BRONZE, STEEL, STAINLESS STEEL, MONEL,  
COPPER NICKEL

### **TEMPERATURE ADJUSTMENT**

The valve can be set to control at any temperature within the limits of the temperature range stamped on the nameplate, by making a simple adjustment to the valve. The Trac Style 'B' temperature regulator has a "warmer" label affixed to the bracket web of all production valves. See Figure 1 for illustration of temperature adjustment mechanism.

To raise the set temperature: Turn the adjusting wheel counterclockwise (looking from the top of the regulator).

To decrease the set temperature: Turn the adjusting wheel clockwise (looking from the top of the regulator).

Wait until the temperature at the bulb stabilizes at one steady reading. It may be necessary to adjust the adjustment wheel incrementally to obtain the desired set temperature.

# TYPICAL INSTALLATION

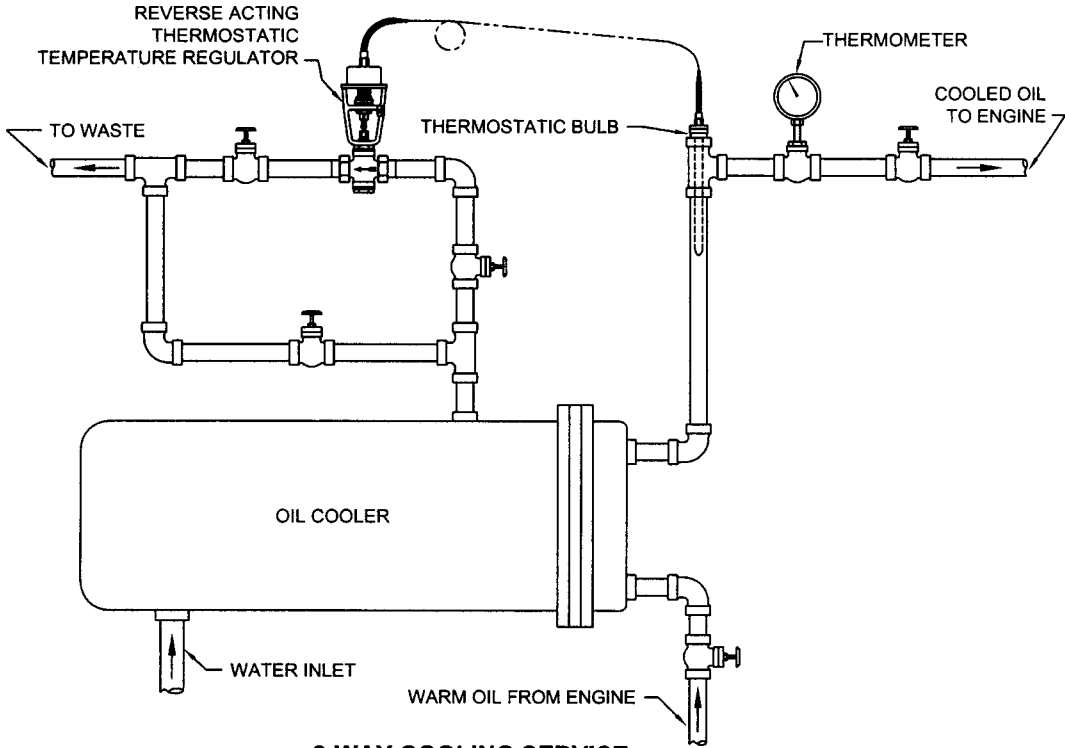

**2-WAY COOLING SERVICE**

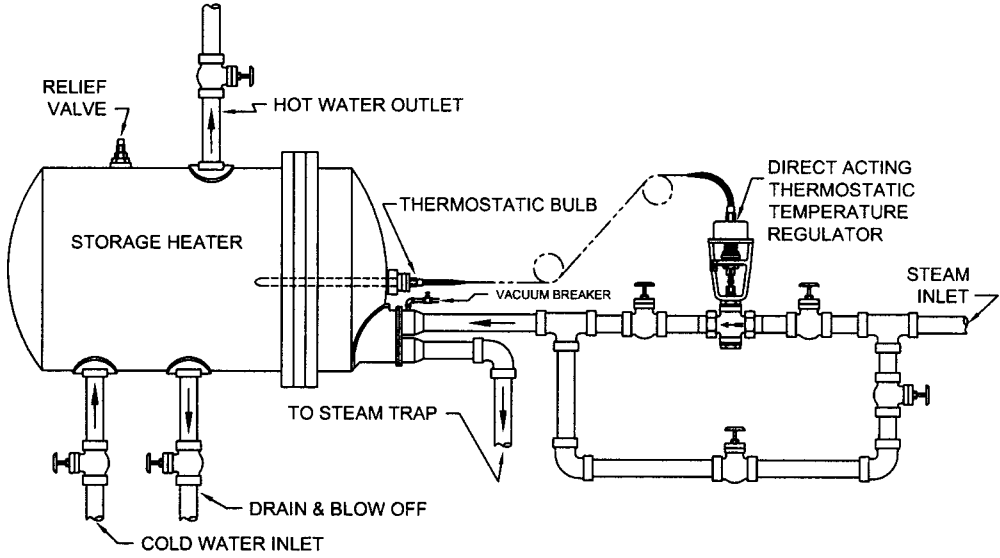

**2-WAY HEATING SERVICE**

# TYPICAL INSTALLATION

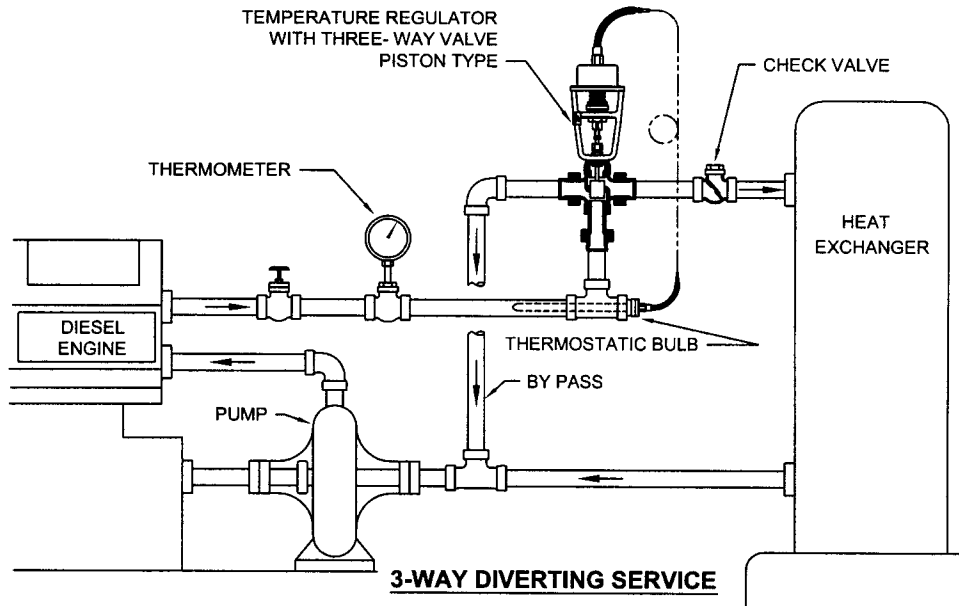
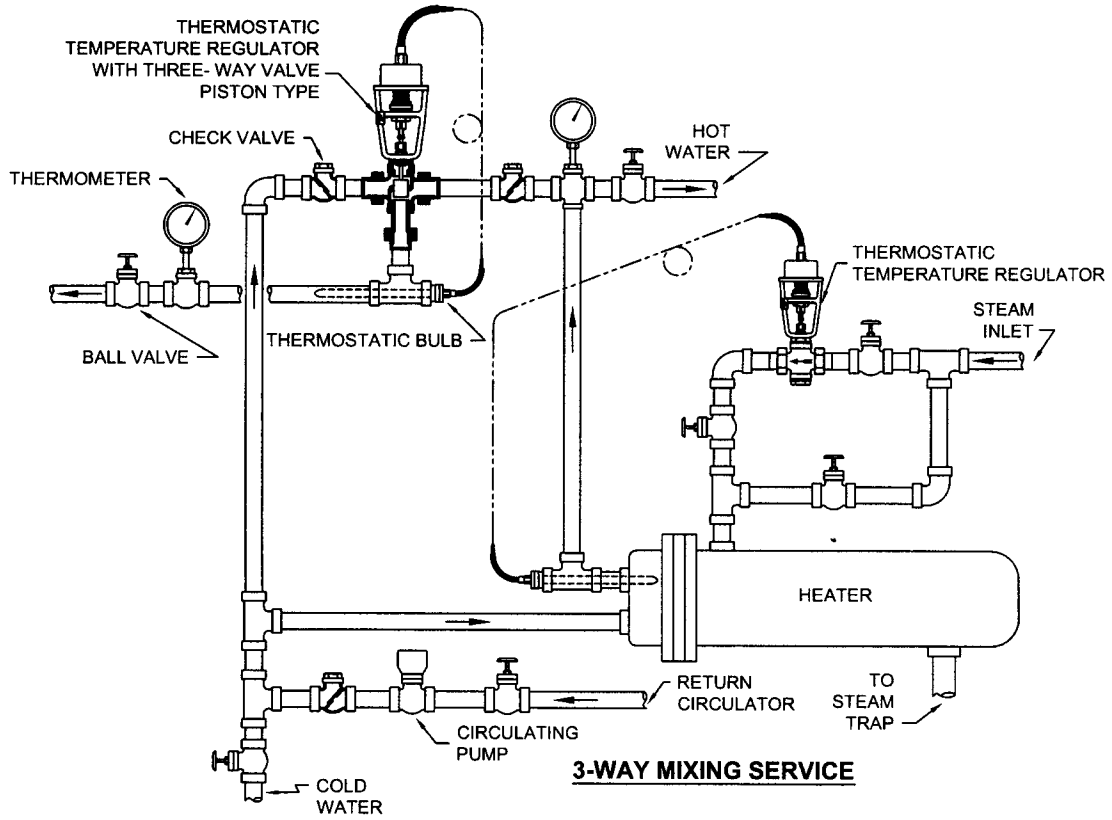

## ORDERING INFORMATION

### MANDATORY INFORMATION

In order to correctly size a temperature regulating valve for a particular application, the user must have a complete understanding of the conditions at the valve. As a minimum, the user should know the following conditions:

SET TEMPERATURE (REQUIRED TEMPERATURE RANGE) This is the temperature that the regulator is required to maintain during normal operation. The valve can be set to control at any temperature within the limits of the temperature range stamped on the nameplate. If the actual set temperature is not known, specify the range of expected temperature settings.

STANDARD RANGES (Deg. F)			
Ranges Starting Under 120 Deg.F		Ranges Starting Over 120 Deg.F	
40-80	80-120	120-160	160-200
50-95	100-140	140-180	200-240

CAPILLARY LENGTH The capillary length from the temperature regulator to the bulb installation location should be kept to a minimum. Generally this length is specified between 8 and 15 feet. Capillary length over 15 feet is available but not recommended. The standard capillary length of the temperature regulating valves described herein is 10 feet.

MAXIMUM INLET PRESSURE This is the maximum pressure that the temperature regulating valve will be subjected to under any operating conditions. This value is used to choose the appropriate pressure rating of the valve and to establish the end connection rating. Be sure to specify whether union end or flanged end connections are preferred.

PRESSURE RATINGS AND AVAILABLE END CONNECTIONS		
RATED PRESSURE (PSIG)	UNION END	FLANGED END
100 (Military)	MIL-F-1183	MIL-F-20042
150 (Military)	MIL-F-1183 (150 Mod)	ANSI-B16.5
250 (Military)	MIL-F-1183	MIL-F-20042
700 (Military)	Not Available	NAVSEA 810-1385861
150 (Commercial)	NPT Tailpiece Available	ANSI-B16.24 or ANSI-B16.5
250 (Commercial)	NPT Tailpiece Available	ANSI-B16.24 or ANSI-B16.5

MINIMUM INLET PRESSURE It is of primary importance to know the minimum inlet pressure at the valve. This value is used in calculating the appropriate size of the temperature regulating valve.

REQUIRED CAPACITY (AT MINIMUM INLET PRESSURE) In most cases inlet pressure varies widely from maximum to minimum inlet pressure values. To correctly size a temperature regulating valve for a particular application, the required flow at minimum inlet pressure must be known.

ALLOWABLE PRESSURE DROP ACROSS VALVE The allowable pressure drop across the valve is also necessary to correctly size a temperature regulating valve. If the actual pressure drop is not known or not given, it is assumed to be 5 psig for sizing purposes.

## REFERENCE DATA

### NAMEPLATE

For specific information regarding an installed Trac Style 'B' temperature regulator, consult the nameplate (Figure 3) affixed to the bracket of each production valve. For operating characteristics of a valve installed in a particular shipboard system consult the applicable certification data sheet or ship's drawing index. When contacting Trac Regulator Co., Inc. regarding troubleshooting, repair, or replacement, please have the following nameplate information available: Valve ID Number and Serial Number.

SPEC	<input type="text"/>				DO NOT POLISH		
TYPE	<input type="text"/>	CLASS	<input type="text"/>	SERIES	<input type="text"/>	SIZE	<input type="text"/>
CAPACITY	<input type="text"/>			RANGE	<input type="text"/>		
BODY	<input type="text"/>	TRIM	<input type="text"/>	STYLE	<input type="text"/>		
VALVE ID	<input type="text"/>			SERIAL	<input type="text"/>		
CID	<input type="text"/>			TECH. MAN.	<input type="text"/>		
TRAC REGULATOR CO. INC. MOUNT VERNON, NY USA							

Figure 3 NAMEPLATE

### CAPACITY TABLES

The water and steam capacity tables provided herein are for reference only and should be used only to determine wide open flow. In applications where accuracy of regulation and flow vs. temperature change requirements are critical, consult the minimum capacity tables of the valve specification (Performance Requirements section 3.5 of MIL-V-19772A or Performance Requirements section 3.4 of MIL-DTL-19772B as applicable).

Note: A typographical error exists in MIL-DTL-19772B Table VII "capacity for type II class 1" valves- units of flow should be indicated in lbs/hr of steam.

### SPACE ENVELOP DIMENSIONS

The space envelope dimensions provided herein are for reference only and should be not be interpreted as the only available valve configurations. Other face to face (flanged) and end to end (union) dimensions are available to meet specific fit requirements. Custom fit configurations may be developed upon request, consult Trac Regulator for more information.

## CAPACITY OF STYLE 'B' DOUBLE SEATED VALVE

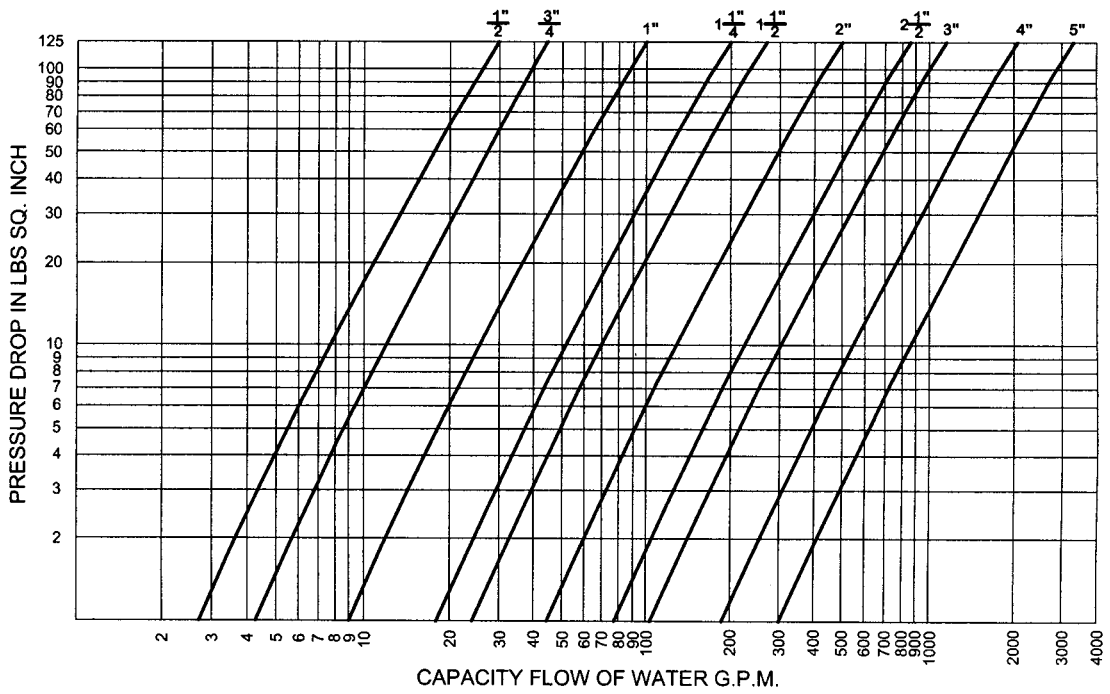

## CAPACITY OF STYLE 'B' 3 - WAY VALVE

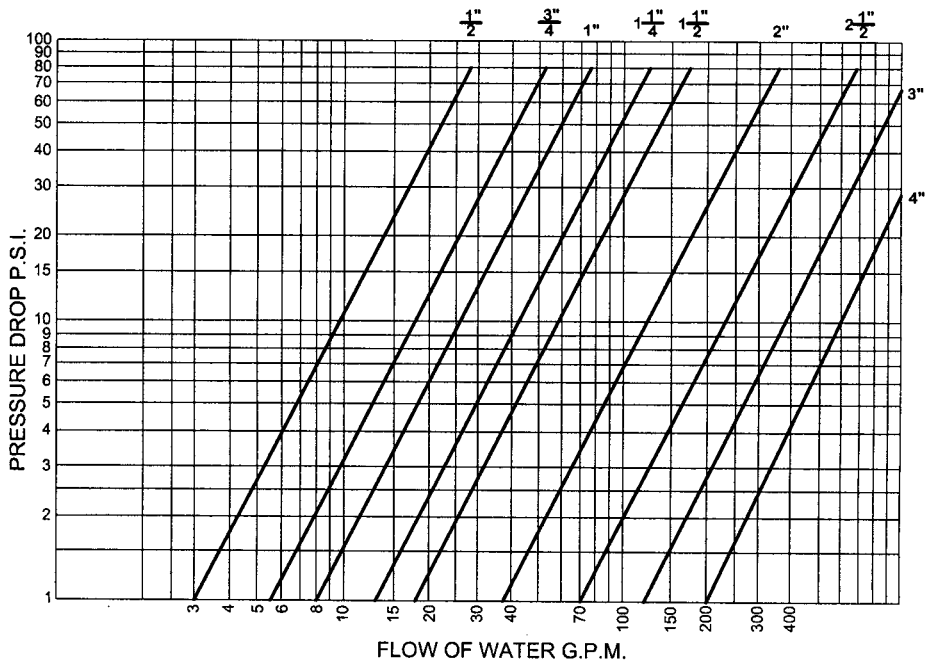

## CAPACITY OF STYLE 'B' DOUBLE SEATED VALVE

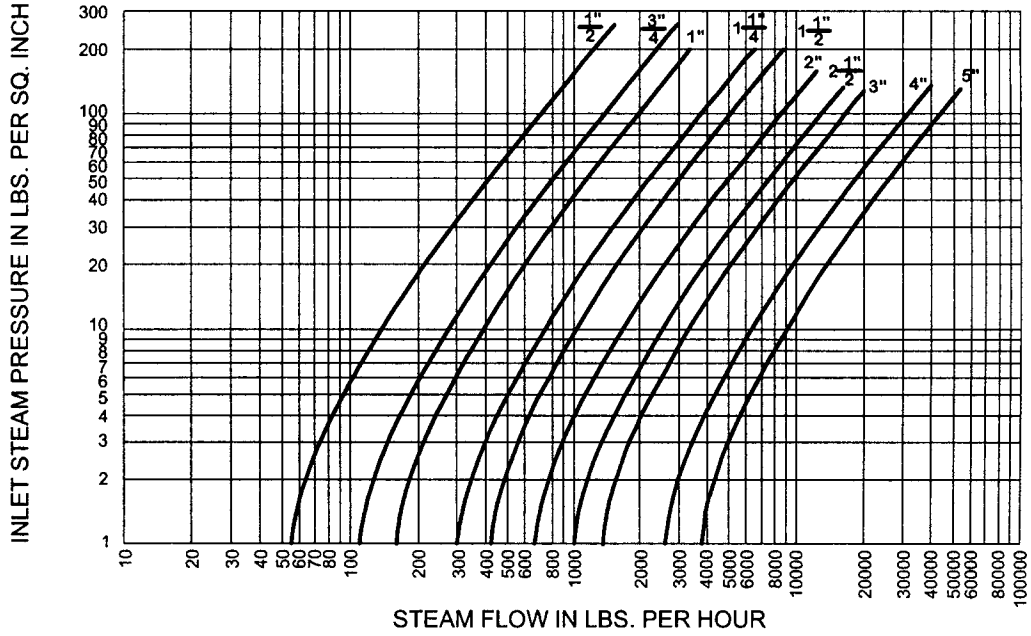

## CAPACITY OF STYLE 'B' SINGLE SEATED VALVE

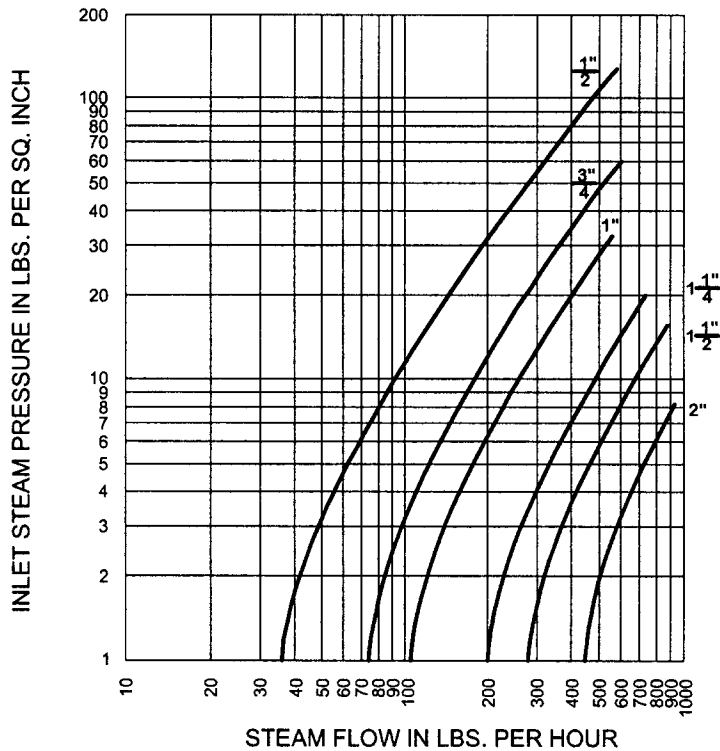



## SPACE ENVELOPE DIMENSIONS

### 2-WAY VALVES

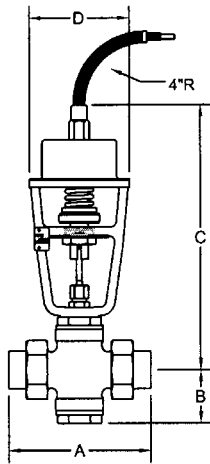

DIRECT AND REVERSE ACTING 1/4" TO 2" MIL-F -1183 UNION ENDS				
2"	9 - 7/32	3 - 3/16	12 - 3/8	4 - 5/16
1-1/2"	7 - 3/4	2 - 7/8	12	4 - 5/16
1-1/4"	7 - 7/32	2 - 9/16	11 - 3/4	4 - 5/16
1"	6 - 5/32	2 - 5/16	11 - 7/16	4 - 5/16
3/4"	6 - 1/8	2 - 5/32	11 - 5/16	4 - 5/16
1/2"	5 - 7/8	2 - 5/32	11 - 5/16	4 - 5/16
3/8"	5 - 7/8	2 - 5/32	11 - 5/16	4 - 5/16
1/4"				4 - 5/16
VALVE SIZE	DIM. A	DIM. B	DIM. C	DIM. D

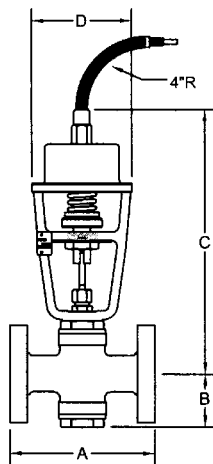

DIRECT AND REVERSE ACTING 1/4" TO 2" MIL- F-20042 150# & 250# FLANGE					
2"	7 - 1/8"	7 - 1/2"	3 - 3/16	12 - 3/8	4 - 5/16
1-1/2"	5 - 1/2"	5 - 1/2"	2 - 7/8	12	4 - 5/16
1-1/4"		4 - 3/4"	2 - 9/16	11 - 3/4	4 - 5/16
1"			2 - 5/16	11 - 7/16	4 - 5/16
3/4"			2 - 5/32	11 - 5/16	4 - 5/16
1/2"			2 - 5/32	11 - 5/16	4 - 5/16
3/8"					4 - 5/16
1/4"					4 - 5/16
VALVE SIZE	DIM.A 150 #	DIM.A 250 #	DIM. B	DIM. C	DIM. D

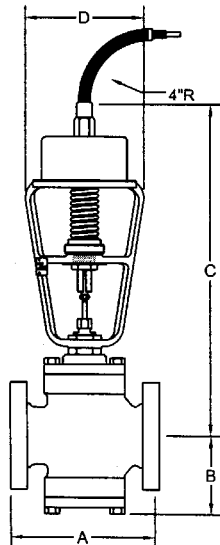

DIRECT AND REVERSE ACTING 2-1/2" TO 6" MIL- F-20042 150# & 250# FLANGE					
6"					6 - 3/4
5"					6 - 3/4
4"	10 - 1/16		5 - 3/8	19 - 5/8	6 - 3/4
3-1/2"					6 - 3/4
3"	8 - 3/8	9 - 7/16	4 - 3/4	19	6 - 3/4
2-1/2"	7 - 5/8	8 - 1/2	2 - 3/8	18 - 3/4	6 - 3/4
VALVE SIZE	DIM.A 150 #	DIM.A 250 #	DIM. B	DIM. C	DIM. D

## SPACE ENVELOPE DIMENSIONS

### 3-WAY VALVES

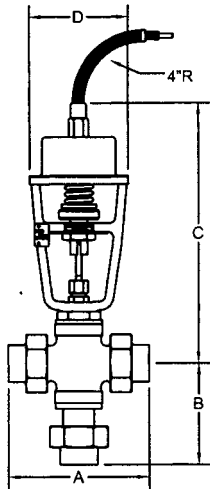

3 - WAY 1/4" TO 2" MIL-F -1183 UNION ENDS				
2"	9 - 1/8	6 - 1/8	12 - 1/4	4 - 5/16
1 - 1/2"	7 - 15/16	5 - 9/16	12	
1 - 1/4"	7 - 15/16	5 - 9/16	11 - 3/4	
1"	6	5	7 - 15/16	
3/4"	6 - 1/8	4 - 3/8	11-13/32	
1/2"			11 - 9/16	
3/8"				
1/4"				4 - 5/16
VALVE SIZE	DIM. A	DIM. B	DIM. C	DIM. D

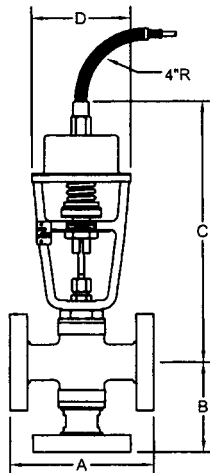

3 - WAY 1/4" TO 2" MIL- F-20042 150# FLANGE				
2"	7	4 - 1/2	12 - 1/4	4 - 5/16
1 - 1/2"	5 - 1/2	5	11-15/16	
1 - 1/4"	4 - 11/16	3-13/16	11 - 3/4	
1"				
3/4"				
1/2"				
3/8"				
1/4"				4 - 5/16
VALVE SIZE	DIM.A 150 #	DIM. B	DIM. C	DIM. D

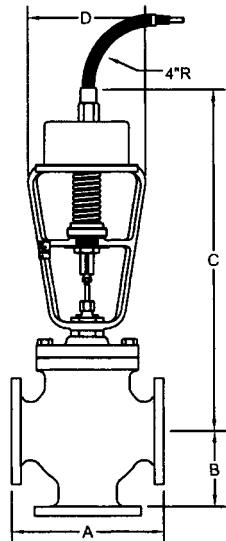

3 - WAY 2-1/2" TO 6" MIL- F-20042 150# FLANGE				
6"				6 - 3/4
5"				
4"	9 - 1/2	6 - 1/8	19 - 1/8	
3 - 1/2"				
3"	9 - 1/2	5 - 1/4	19 - 5/8	
2 - 1/2"	8 - 3/4	4 - 7/8	19 - 3/8	6 - 3/4
VALVE SIZE	DIM.A 150 #	DIM. B	DIM. C	DIM. D

